

Subject: Level detectors, level sensors, tank level monitoring

NOTES ON THE USE OF LEVEL DETECTORS

This app note describes the recommended procedure for building up a level detector assembly for use in tanks, vats, ponds and other applications.

This particular app note addresses the use of the IMO/GEM Sensors division float switches, model number LS-7, Type VII, PolyPro. These are 6 inch long, 0.5 inch diameter sealed float switches with 1/2 inch NPT fittings, which are rated for light duty use only (20VA, Max). They are constructed of Polypropylene which is excellent for use in food grade applications and give long life in both fresh and salt water tanks.

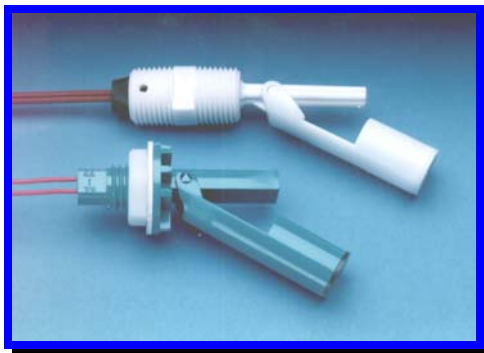

A simple four state level sensor may be constructed using the GEM sensors shown at left top. The assembly is shown in the sketch below:

The level sensor is built up using ordinary 1/2 inch PVC plastic pipe fittings. For use in tanks, we generally put a hook on the end on the assembly to catch on the tank wall. In some cases, it is necessary to weight the end of the assembly to hold it vertical in the tank.

An old air stone makes a perfect weight (and it's food grade). Total cost: about \$45.00.

The level sensor arrangement shown will indicate if the tank is at a low state, a normal state, a high state, and if the sensor, or cable is broken. Note the peculiar arrangement of the sensors (one down, or closed, and one up, or open). The logic table and a schematic for the MCU interface are shown below.

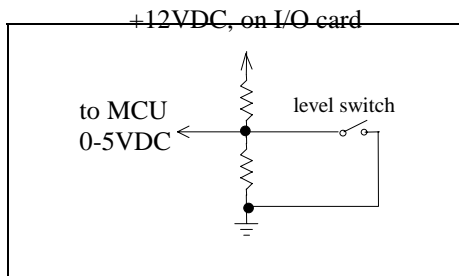
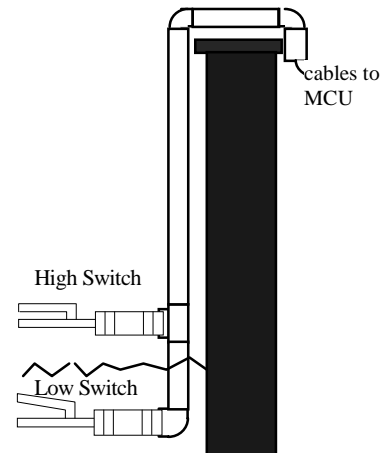

| Bit Condition, at the MCU | High Switch State (bit 1) | Low Switch State (bit 0) |
|---------------------------|---------------------------|--------------------------|
| High Water | 1 | 1 |
| Normal (shown) | 0 | 1 |
| Low | 0 | 0 |
| Bad sensor | 1 | 0 |

As can be seen from the schematic, when a switch is in the closed state, the MCU sees a 0 volt output from the Input/Output (I/O) card, which is the same as a zero or 0 logic state. When the switch is open, the MCU sees a 5 volt signal, due to the voltage divider network of the resistors, which corresponds to a 1 logic state.

The level sensor described in this app note is a two bit sensor. That is, the width of the digital word for this sensor is two binary bits wide. Each bit has two states, on or off, for a total of four possible states. In this application, we call the low water sensor bit 0, and the high water sensor bit 1. When connecting the actual signal wires to the MCU, you may choose any 2 bit pair of bits as long as they are sequential bits, and you connect bit 0 (the low water sensor line) to the lowest order bit (otherwise you would have to reverse the table). The MCU500 supports up to 64 digital input bits. So choose two, say, bits 27 and 28. Connect the low water sensor to bit 27 input, and the high water sensor to bit 28 input. The data base would then be set up with a channel specifying the channel source as a digital word, of 2 bits width, starting at bit 27. The calibration table would be given a name and entered into the data base as shown in the table above. Similarly, an alarm table is generated for the channel. This specifies what messages to send, to where, and on what conditions.

One of the fundamental concerns of proper instrument design is instrument failures, and especially those resulting in false readings, or worse yet, no reading at all when an alarm state really exist. There are several possible failure modes for a level sensor of this type, and using the typical MCU I/O interface. The first is a ruptured or disconnected cable. If this happens, the MCU will detect a **11** state which, if possible, should be an alarm state. And it is; it's the high water alarm state. So the high water state (**11**), which would normally indicate a real high water alarm condition in the tank, could indicate that for some strange reason, the cable got disconnected.

Similarly, if the cable is shorted, as in a salt water short, or if sensor power is lost, the MCU will detect a **00** state. This, too, should simulate an alarm state, where both bits are zero (both switches are closed). And it does; the low water state.

The "normal" state (as shown in the table and on the diagram) is the **01** state, where the high water switch is down, or closed, and the low water switch is raised (floating) or open. If, as sometimes happens, the lower switch gets broken, and it's submerged under (salt) water, then it very likely will short out, simulating a zero state. This, too, will simulate the **00**, or low water alarm state. The low water alarm state, therefore, not only indicates that the tank is probably low on water, but it will also catch those potential failures of a salt water intrusion in the cable, or into a switch housing or conduit, or a possible broken switch.

It should be obvious that the **10** state is an illegal state. If the MCU detects this state (yes, it is a valid number, so it has to be programmed in the data base table), it should send an alarm for "invalid sensor" reading.

There is one possible failure mode which this scheme will not detect: if the upper or high water switch is broken, and salt water gets into it, it will short out. If the tank proceeds to fill up, past the high water alarm state, the sensor will continue to report a **01**, or normal state. To address this possible situation a different approach must be used. The normal state is also the condition where the high water level switch is out of the water, and visible. It is therefore possible for the operator to routinely check the sensor for possible damage. In fact, the operator can test the system by simply raising the switch float and forcing the alarm. If the switch shows no damage, and the housing for the switch sensor is solid, and if the alarm sounds, all is well. Otherwise, the sensor should be replaced.

Procedures such as this should become part of the routine maintenance of the plant. And a word of caution: if float switches, or any kind of mechanical switches, are to be used in an area where possible damage to the switch is probable (high traffic areas), then enclose the switch. A 6 inch sewer pipe works quite well as a shield around the switch assembly, and tie wraps can be used to attach it to the same 1/2 inch riser pipe the float switches are mounted to. When constructing the float switch assembly, always use Teflon tape on all joints, and coat any electrical connections (we typically use crimp connectors) inside the pipe with liquid electrical tape. Duct putty is generally used to seal off the open end of the pipe, outside the tank.

Broken switches, and leaking pipes or conduits can cause instruments to “short out” to earth ground. Our instrument systems are designed to handle such shorts, without causing any harm to humans, or product. There is absolutely no shock hazard or other potential hazard, even if the switches break off, exposing bare wires. The interfaces to our instrument systems are also protected against any reverse currents which may result from some other system failure, like a broken submersible heater. But there is a problem: All mechanical switches require what is known as a seizing current to make sure the contact properly closes and electrical current flows in the circuit. The MCU reduces this current to the minimum necessary, about 1 milliamp (at a dead short). This current is still enough to cause electrolysis. That is, if salt water were to get into a connector, or intrude into the electrical wiring in a conduit and into the wire connections, the small currents will eventually eat the heck out of the wiring and connector pins. First the pins in the connector get a discolored, sort of a grayish look to them (even expensive gold plated pins!). Then holes start to appear; then the whole pin disappears or breaks off. Electrolysis can, and does, destroy expensive connectors and instruments. If salt water gets inside an instrument onto the printed circuit wiring boards, it will literally eat the plated wires right off the board.

In general, we recommend using plenty of Teflon tape to seal joints, and liquid electrical tape to seal connections. Removable electrical connectors may be sealed with self vulcanizing electrical rubber tape. Another excellent sealant is GE RTV 162, a white silicone rubber adhesive sealant. It is specifically formulated for use on electrical and electronic equipment. It is non-corrosive to metals or other substances (most other RTV's are corrosive), and it has a low volatility content and low odor. This is an excellent sealant for connectors, and it can be easily cut or peeled off to remove it. We use it in the 10 ounce tube size, which fits in a standard caulking gun. By the way, if you have any other great techniques, please share them.

A final word on float or level switches. In general, such switches are constructed using what is known as a reed switch. It operates by bringing a small magnet near it. The magnet is located in the float arm. You can tell if it's a reed switch by bringing a magnetic compass near the switch body and watching the needle swing strongly toward the switch magnet.

Reed switches can be operated by ANY strong nearby magnetic field, even the field set up near a pump (especially the magnetically coupled pumps which so many of the low cost food grade pumps are now). DO NOT co-locate the float switch near any pumps or other electrical devices which could produce a strong field. The switch will operate erratically! (and wake you up at 4 AM sending false alarms!). If in doubt, use a small magnetic compass (like the one you got with your DTV or at the toy store) and check the area. If the needle swings erratically, or is pulled off magnetic north, then re-locate the switch, or find and re-locate the source of the disturbance. And DO check the switch magnets often (at least until you're familiar with the environment). Minute magnetizeable particles do attach themselves to the float and, in time, it gets covered with junk, making it inoperable.

